

4" Recessed Housing

MODEL ODH2-4IA2

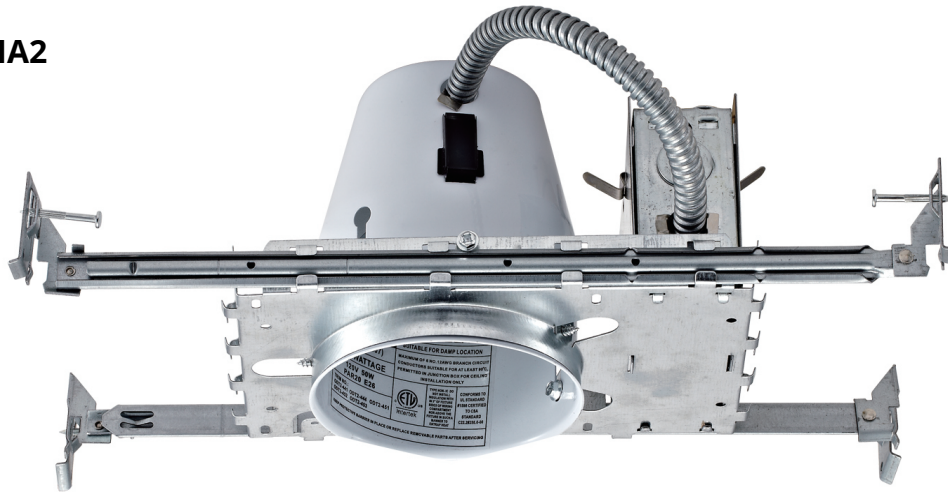

HIGHLIGHTS

- Meets State of WA energy code ASTM E283 for Air Tight
- Wire through junction box and adjustable hangar bar from 14"-24"
- Comes with thermally protected with shut off sensor and is rated for damp locations
- Commercial / residential grade new construction E26 base R30/PAR20 Max. line voltage Air-Tight recessed housing

SPECIFICATIONS

Model	ODH2-4IA2
Lamp Type	E26 base R30 / PAR20 50W Max.
Input/output Voltage	120V AC
Mounting	Four-sided
Application	Commercial / Residential
Included	Detachable socket / Push-in connectors / Cover to protect exposed cone from paint

DIMENSIONS

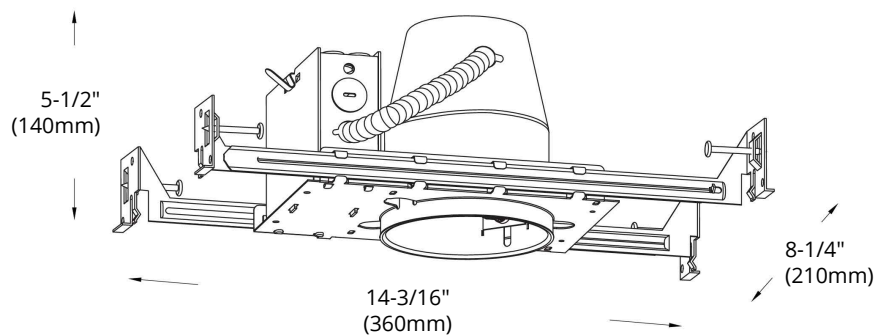

Reference	QTY.	Remarks	Project:
			Location:
			Architect:
			Engineer:
			Contractor:
			Submitted by:
			Date:

ORTECH reserves the right to modify at any time, without notice, any or all of our product's features, designs, components and specifications to meet market changes.