

LED Patio String Lights

MODEL PL50FT-3000K



HIGHLIGHTS

- 50ft patio string light with 24 sockets + 2 spare lamps and 21-5/8" (550mm) spacing perfect for any outdoor patio or lighting display
- This commercial E26 medium base light stringers are weather resistant and designed for long term usage
- Its E26 base sockets are excellent for any standard LED or incandescent bulbs, giving you the creative freedom for your lighting display
- Includes guy-wire loop for additional support for large spans or spaces

FEATURES

- Great decorative lighting product for patios, gazebos, building outlines, event tents, and retail walkways
- Factory-molded, formulated PVC sockets on heavy-duty wire form a tight weather resistant seal around bulbs
- E26 medium base decorative bulbs are included

SPECIFICATIONS

Model	PL50FT-3000K
Wattage	1.2W per bulb
Voltage	120V AC
Lumens	N/A
Beam Angle	270°
Lifetime	35000 hours
CRI	80
Dimmable	No
Lamp	E26 base glass body
Wiring	SJTW 18AWG cable
Rating	Non-IC Rated / Outdoor use / for Wet locations
Grade of Protection	IP 44
Application	Garden / Gazebos / Building outlines / Event tents / Retail walkways
Colour Temperature	3000K (Warm White)
Operating Temperature	-20°C ~ +40°C
Warranty	2 years for the bulbs

LED Patio String Lights

MODEL PL50FT-3000K

DIMENSIONS

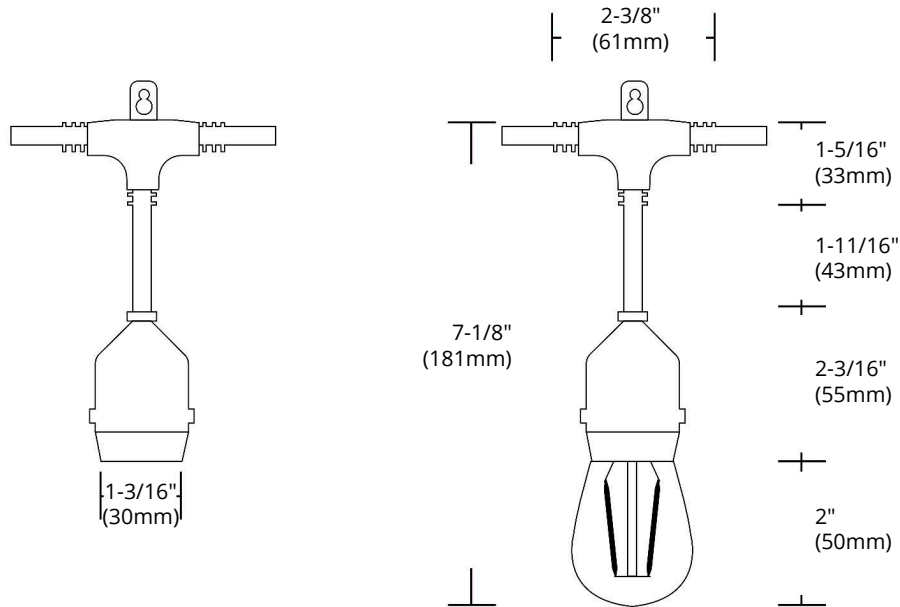
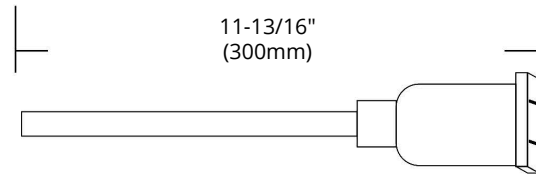
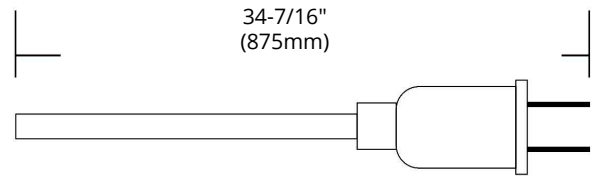
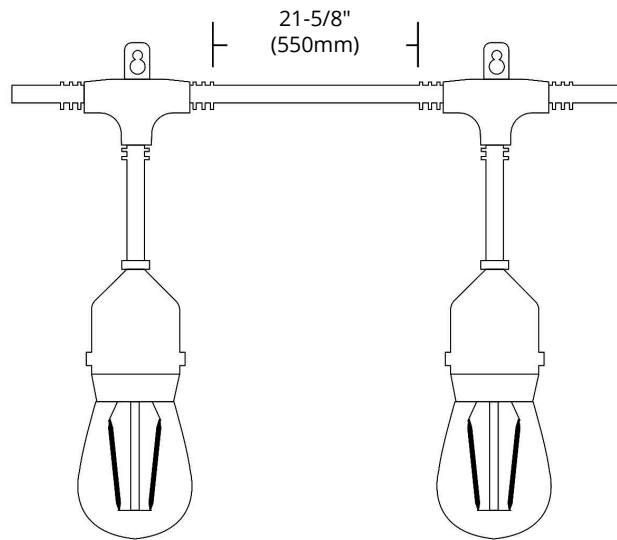

Reference	QTY.	Remarks	Project:
			Location:
			Architect:
			Engineer:
			Contractor:
			Submitted by:
			Date:

ORTECH reserves the right to modify at any time, without notice, any or all of our product's features, designs, components and specifications to meet market changes.