

MODEL BOX 54171-FB

HIGHLIGHTS



- Size: 4" x 4" x 2-1/8"
- Made of galvanized steel
- Octagon ceiling fan support box
- Max weight 70 lbs for fans, 200 lbs for chandeliers

SPECIFICATIONS

Model	BOX 54171-FB
Application	Ceiling fan support
Material	Galvanized Steel
Box Type	Octagonal box
Construction Type	Drawn
Cover Included	None
Knockout Options	Side: 2-1/2" Bottom: 1-1/2"

DIMENSIONS

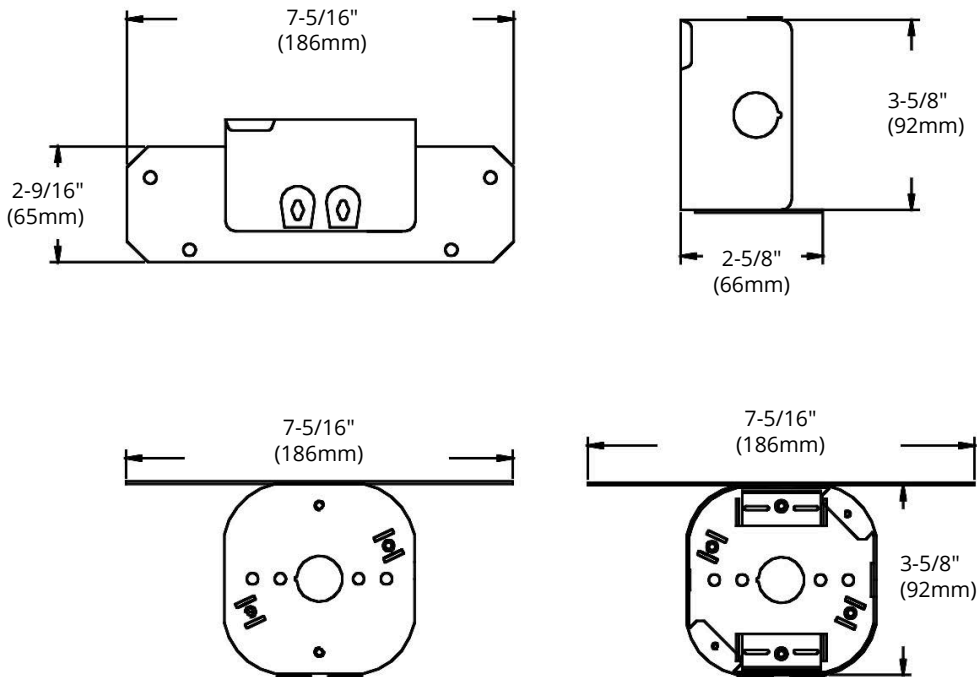

Reference	QTY.	Remarks	Project:
			Location:
			Architect:
			Engineer:
			Contractor:
			Submitted by:
			Date:

ORTECH reserves the right to modify at any time, without notice, any or all of our product's features, designs, components and specifications to meet market changes.