

LED Linear High Bays

MODEL OL-HB5-225W



HIGHLIGHTS

- Commercial grade linear high bays available in 4 feet
- Suspended, surface-mounted, or pole-mounted installation
- Environment friendly — no heat produced during usage
- 4 pieces 1 meter in length chains included per packaging

SPECIFICATIONS

Model	OL-HB5-225W
Wattage	225W
Voltage	120-347V
Lumens	29250 lmn
Beam Angle	120°
Lifetime	50000 hours
CRI	> 80
Dimmable	Yes(only 0-10v dimming available)
Rating	Non-IC Rated, Indoor use only, for both Dry / Damp location
Grade of Protection	IP 20
Applications	Warehouses / Gymnasiums / Industrial spaces, etc.
Colour Temp.	4000K (Natural White)
Operating Temp.	-20°C ~ +40°C
Chains Included	4 pieces, 1 meter in length

MODEL OL-HB5-225W

DIMENSIONS

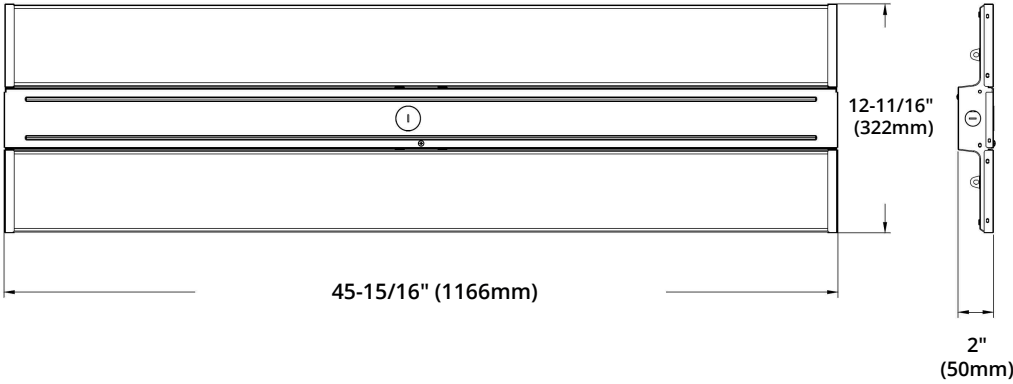

Accessories (sold separately)



Pendant Hanger

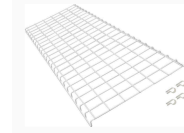

Wire Guard

1165 mm x 334 mm x 18 mm

TESTING REPORT

LUMINOUS INTENSITY DISTRIBUTION DIAGRAM

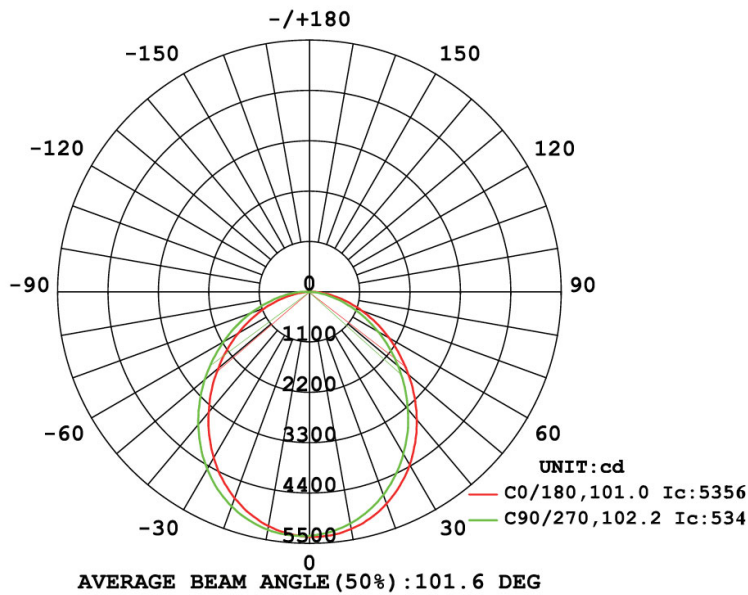

C0 PLANE ISOLUX DIAGRAM (UNIT:lx)

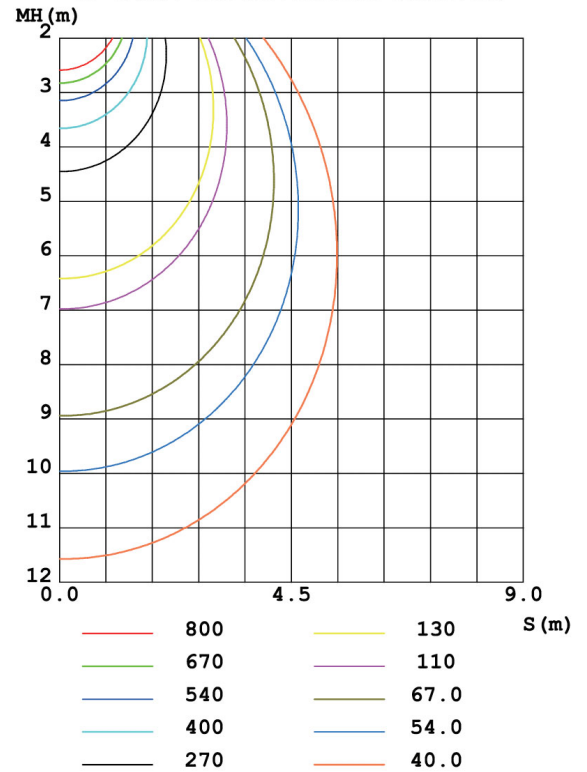

Reference	QTY.	Remarks	Project:
			Location:
			Architect:
			Engineer:
			Contractor:
			Submitted by:
			Date: