

## MODEL SDF200-2



### HIGHLIGHTS

- Can be ceiling or wall mounted
- Superior European designed external rotor motor technology increases performance under any extreme restrictive duct design
- Includes a hinged access door with integrated mounted motor to simplify period servicing

### SPECIFICATIONS

Model	0.1"	0.2"	0.3"	0.4"	0.5"	0.6"	0.7"	0.8"	0.9"	1.0"	Amps (FLA)	Fan Speed (RPM)	Sone
SDF200-2	235	222	211	205	195	186	175	169	158	150	0.9	2600	2.5

Model	Dimensions	Dual Intake	Discharge
SDF200-2	10-1/2" x 11" x 6" (267mm x 279 mm x 152mm)	4" (102 mm)	5" (127 mm)

#### Add ons (Optional)



**Amp Sensor**  
AS-0, AS-5



**Pressure Sensor**  
SDS-10

- Fan Weight: 12 lb | Case Quantities: 1

### HOUSING

- Built-in back draft damper
- Painted galvanized steel housing
- Double inlet collars for dual exhaust
- Hinged impeller for ease of cleaning and maintenance

### MOUNTING

- Designed to be ceiling or wall mounted
- Rubber grommets MUST be attached to isolate housing from the structure (Rubber grommets are pre installed on mounting bracket)
- Supplied with two permanently attached brackets with pre-drilled holes for easy installation

### MOTOR / BLOWER

- Power rating should be 120V/60Hz
- Backward inclined blower wheel for smooth & quiet operation
- Motor comes with a built-in overload disconnect for safety & longer motor life
- Capacitor start external rotor 4 pole motor comes with a lifetime lubrication for continuous operation

**SDF200 Dimensions Diagram**

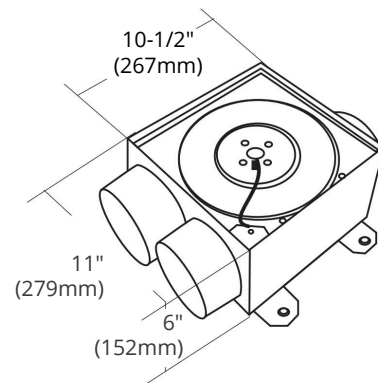

Reference	QTY.	Remarks	Project:
			Location:
			Architect:
			Engineer:
			Contractor:
			Submitted by:
			Date:

ORTECH reserves the right to modify at any time, without notice, any or all of our product's features, designs, components and specifications to meet market changes.