



HIGHLIGHTS

- Ultra Silent, High Performance DC Motor, Built-in Humidity Sensor (both ODD-100HS and ODD-100HS+MS) and Motion sensor (ODD-100HS+MS)
- Built-in Humidity Sensor detects range from 50-100% rh
- Very quiet fan for ceiling or wall mounted Hold and ETL evaluation and conform to UL and cUL safety standards. HVI and ENERGY STAR® certified
- It comes with a DC motor which is known for its high efficiency and long lasting reliability. It holds an ETL evaluation and conforms to UL and cUL safety standards

SPECIFICATIONS

Model	ODD-100HS ODD-100HS+MS					
Static Pressure in inches w.g.	0.1	0.25	0.1	0.25	0.1	0.25
Air Volume (CFM)	54.5	42.8	80	62.7	100	81.2
Noise (sones)	0.1	0.9	0.4	0.8	0.7	1.0
Fan Watts	3.3W	5.7W	4.9W	7.5W	8W	9.2W
Duct Diameter	4"					
Power Rating (V/Hz)	120/60					

- **Housing Size:** 8-1/2" x 9" x 5-3/4" (216 mm x 229 mm x 146 mm)
- **Grille Dimensions:** 11-13/16" x 11-7/16" (300 mm x 290 mm)
- **Fan Weight:** 7 lb
- **Case Quantities:** 6

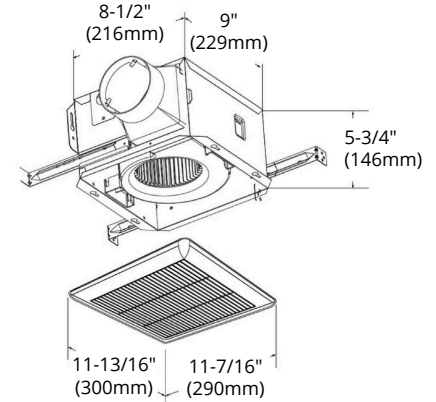

HOUSING

- Made of rugged 26 GA galvanized steel
- Detachable 4 inch polymeric collar which includes a light weight built-in back draft damper

MOTOR / BLOWER

- 50-100% ADJUSTABLE Humidity Sensor
- 3 SPEED DC motor fan with low energy consumption
- 30 CFM variable 24 hour operation LOW SPEED adjustable speed controller allows accurate cfm selection
- LOW SPEED adjustable speed controller allows accurate cfm selection
- DC MOTOR comes with thermal cut off protection
- QUIET operates at lower rpm to ensure low sone levels

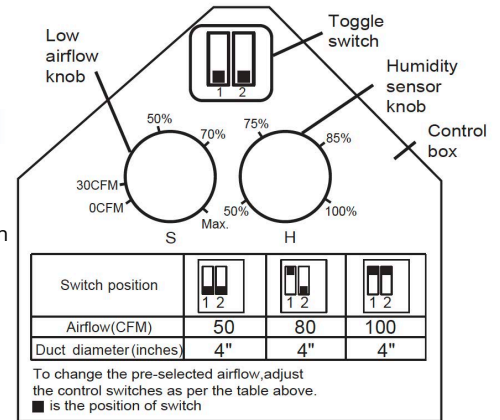

GRILLE

- The grille is low profile that has elegance and still able to maintain its simplicity

TYPICAL SPECIFICATIONS

- Ceiling ventilator shall have corrosion resistance galvanized steel
- It shall be ducted to a roof vent or wall cap using 4 inch round pipe
- Blower assembly shall be removable, have a centrifugal type blower wheel and a permanently lubricated motor designed for continuous operation
- Includes an attachable non-metallic collar with built-in back draft damper
- Air and sound delivery meet the ENERGY STAR® certified ratings as per the fan curves attached



Comes with protective cardboard cover

Warranty is voided if the cardboard is removed anytime during construction.

Reference	QTY.	Remarks	Project:
			Location:
			Architect:
			Engineer:
			Contractor:
			Submitted by:
			Date: